

自由式虎鉗
FREE TYPE VISE

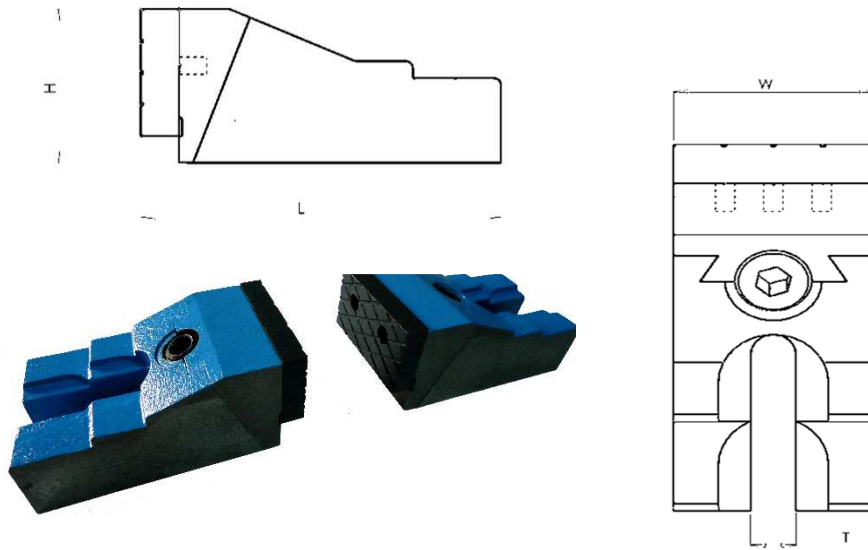

- ※ Material of main body: FCD 45 (Ductile iron)
- ※ Operate the pair of vises freely on slotted machining table in accordance with the appearance of working pieces.
- ※ Hardness of front clamping teeth: HRC 52±3°
- ※ sales by pair including vice x 2 pcs, T nut x 4 pcs, Flange nut x 4 pcs, stud x 4 pcs.

Order no.	Dimension WxHxLxT (mm)	Gross weight (KG)	attached components
FV-11062	62X55X134X14	4.7	M12 or 1/2" nuts , 3" length studs
FV-11085	85X73X157X18	10	M16 or 5/8" nuts , 4" length studs
FV-11125	125X98X190X20	22	M20 or 3/4" nuts , 5" length studs